

# VESSELVIEW LINK INSTALLATION KIT

**IMPORTANT:** This document guides our dealers, boatbuilders, and company service personnel in the proper installation or service of our products. If you have not been trained in the recommended servicing or installation procedures for these or similar Mercury Marine products, have the work performed by an authorized Mercury Marine dealer technician. Improper installation or servicing of the Mercury product could result in damage to the product or personal injury to those installing or operating the product. Always refer to the appropriate Mercury Marine service manual for component removal and installation instructions.

**NOTE:** After completing installation, place these instructions with the product for the owner's future use.

## Components Contained in Kit

Qty.	Description	Part Number
1	VesselView Link—single engine	NSS
	VesselView Link—multiengine	
1	VesselView Link harness	8M0111670
1	NMEA 2000® extension harness	8M3002269
1	NMEA 2000 T-connector	8M6002266

## Precautions for Wiring and Harnesses

**IMPORTANT:** Refer to the following precautions to avoid damage to the electrical system when working on or around the electrical harness or when adding other electrical accessories.

- Do not attempt diagnostics without the proper approved service tools.
- Do not puncture wires for testing (probing).
- Do not splice wires into the harness.
- Do not connect, network, tie into, switch, or sink source voltage or current from the wiring harnesses.
- Do not connect any type of communication or navigation equipment to the wire harnessing other than at the designated connection point.
- Install boat accessory equipment using an appropriate power source connection, such as a fuse panel or junction box circuit breaker.
- Do not tap directly into any of the electrical wiring harnesses for a source of power.

## Guidelines for Installing Harnesses

Follow these guidelines when installing the harnesses:

- The maximum CAN bus length is 70 m (230 ft).
- The maximum length of a CAN bus drop (branch off the main harness) is 7 m (23 ft).
- The combined length of all drops cannot exceed 36 m (118 ft).
- Locate an appropriate path for routing the harness connections to their installation points.
- Inspect the routing path to ensure that the surfaces are free of any sharp edges or burrs that could cut the harness.
- Fasten and support the harness with clamps or cable ties along the routing path. A clamp or cable tie must be used within 25.4 cm (10 in.) from any connection and every 45.8 cm (18 in.) along the routing path if the harness is not housed in a rigging tube.
- Ensure that all connections are tight and locked (if equipped with a lock mechanism).
- Seal all unused connectors with weather caps.
- Route the harness at least 1 m (3 ft 3 in.) from any device that produces electromagnetic interference (EMI), such as VHF radio and radar equipment.

## VesselView Link Installation

1. Select a suitable location for mounting the VesselView Link module. Consider the following guidelines:
  - Adequate construction of the mounting area to support the VesselView Link module
  - Will not interfere with access to under-helm areas for service
  - Adequate space in front of the module for harness connections—10.6 cm (4.17 in.) recommended
  - Location will not cause the operator to bump into the VesselView Link unit with their leg or knee
  - Location will not cause interference with the helm, throttle and shift, or joystick controls

## VESSELVIEW LINK INSTALLATION KIT

- Adequate space for SD card access—5 cm (1.97 in.) recommended
  - Located within reach of the NMEA 2000 bus and the SmartCraft junction box for extension harness connection
2. Use the VesselView Link module as a template to mark the mounting hole locations. Refer to the following illustration for mounting dimensions and clearances.

**NOTE:** If mounting the bracket to a fiberglass surface, apply masking tape before drilling the pilot holes. This will help prevent the fiberglass from chipping or cracking.

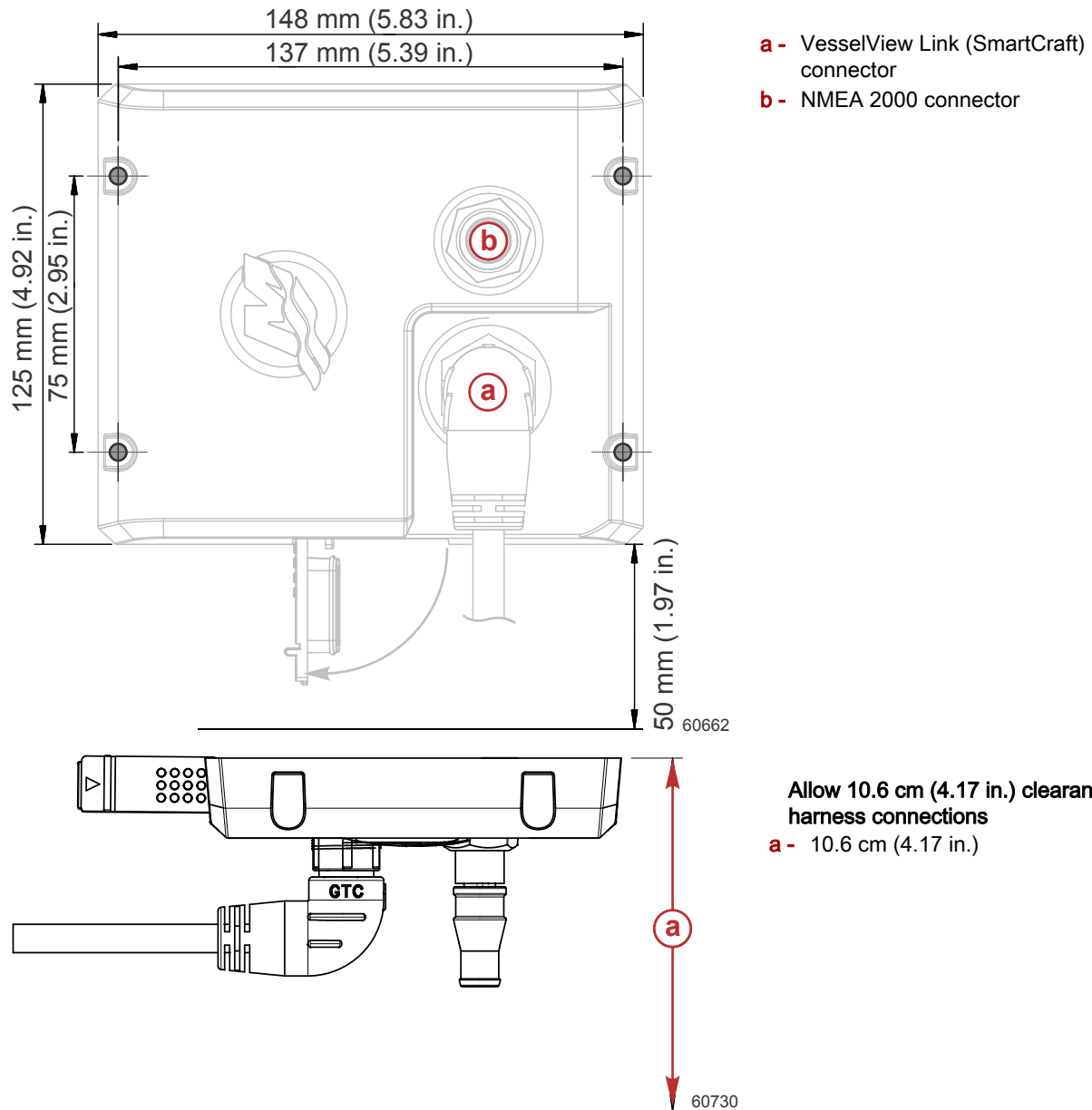

3. Use a #29 drill bit (0.136 in.) to drill the four pilot holes to mount the VesselView Link module.

4. Mount the VesselView Link with the supplied mounting screws.

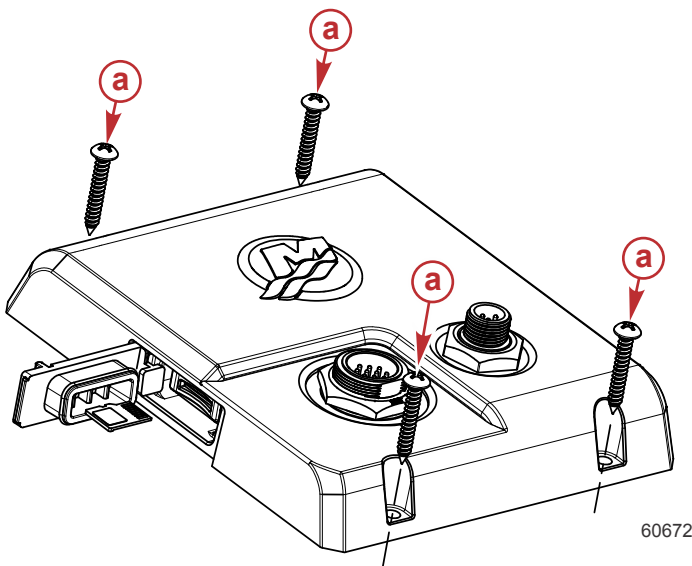

a - Mounting screws (4)

## VesselView Link Harness Connection

1. Connect the VesselView Link harness to the SmartCraft junction box. Different connection options may exist, depending on your application. Refer to the connection guidelines in the following list.  
**IMPORTANT: Connecting the VesselView Link harness to the multiwake SmartCraft junction box for multiengine Digital Throttle and Shift applications, or using a dual engine instrument adapter for mechanical throttle and shift applications is required to allow the VesselView Link module to be powered up when either key switch is turned on.**
  - a. **For single engine DTS applications**—connect the VesselView Link harness to the SmartCraft junction box.
  - b. **For multiengine DTS applications**—connect the VesselView Link harness to the multiwake SmartCraft junction box.
  - c. **For dual engine mechanical throttle and shift applications**—connect the VesselView Link harness to the SmartCraft junction boxes using a dual engine instrument adapter.
2. Install the NMEA 2000 T-connector into the NMEA 2000 backbone.

3. Connect the NMEA 2000 extension harness to the NMEA 2000 T-connector.

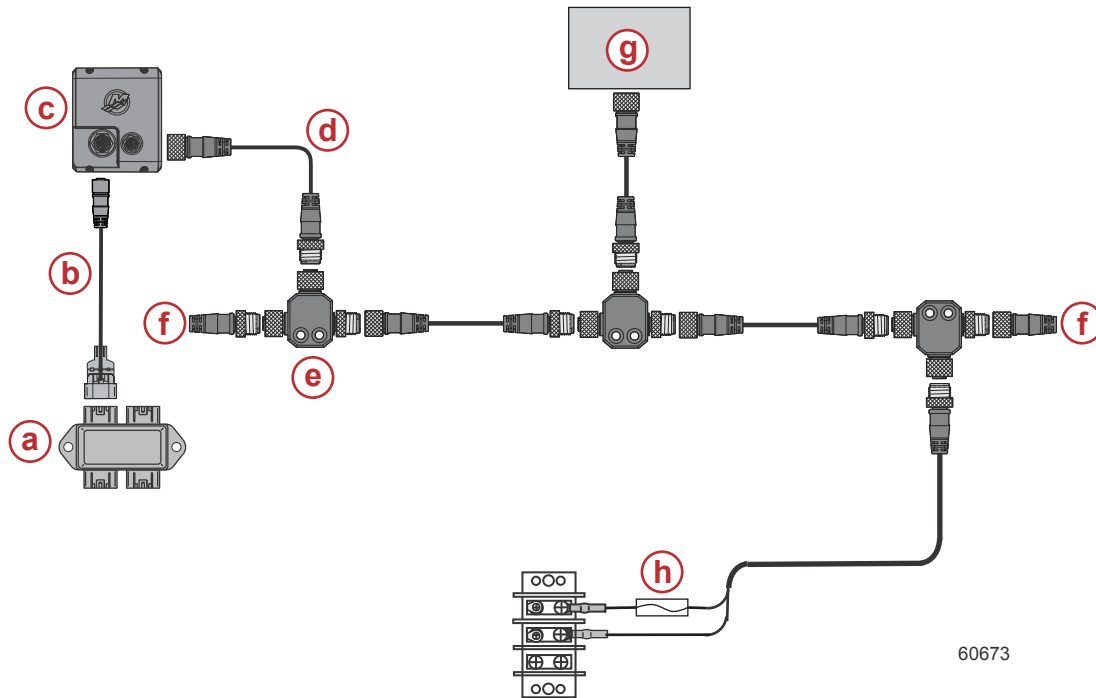

60673

- a** - SmartCraft junction box
- b** - VesselView Link harness
- c** - VesselView Link
- d** - NMEA 2000 extension harness
- e** - NMEA 2000 T-connector
- f** - Termination resistor
- g** - Chartplotter
- h** - NMEA 2000 fused power source

4. Connect the VesselView Link harness and the NMEA 2000 extension harness to the appropriate connectors on the rear of the VesselView Link module.

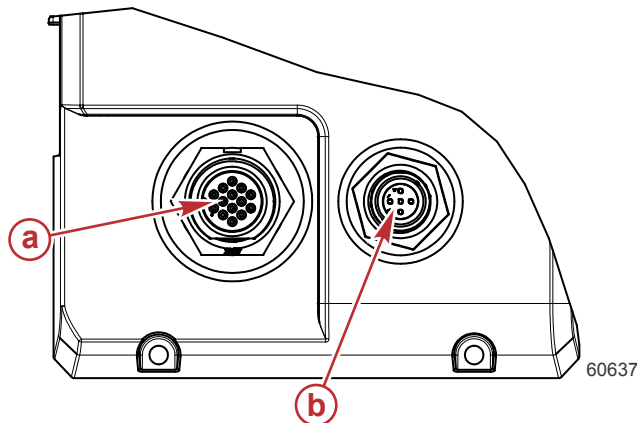

60637

- a** - VesselView Link (SmartCraft) connector
- b** - NMEA 2000 connector

**Products of Mercury Marine**  
 W6250 Pioneer Road  
 Fond du Lac, WI 54936-1939

© MERCURY MARINE. All rights reserved. Reproduction in whole or in part without permission is prohibited. Alpha, Axis, Bravo One, Bravo Two, Bravo Three, Circle M with Waves Logo, K-planes, Mariner, MerCathode, MerCruiser, Mercury, Mercury with Waves Logo, Mercury Marine, Mercury Precision Parts, Mercury Propellers, Mercury Racing, MotorGuide, OptiMax, Quicksilver, SeaCore, Skyhook, SmartCraft, Sport-Jet, Verado, VesselView, Zero Effort, Zeus, #1 On the Water and We're Driven to Win are registered trademarks of Brunswick Corporation. Pro XS is a trademark of Brunswick Corporation. Mercury Product Protection is a registered service mark of Brunswick Corporation.